

Pre-fabricated timber floor system

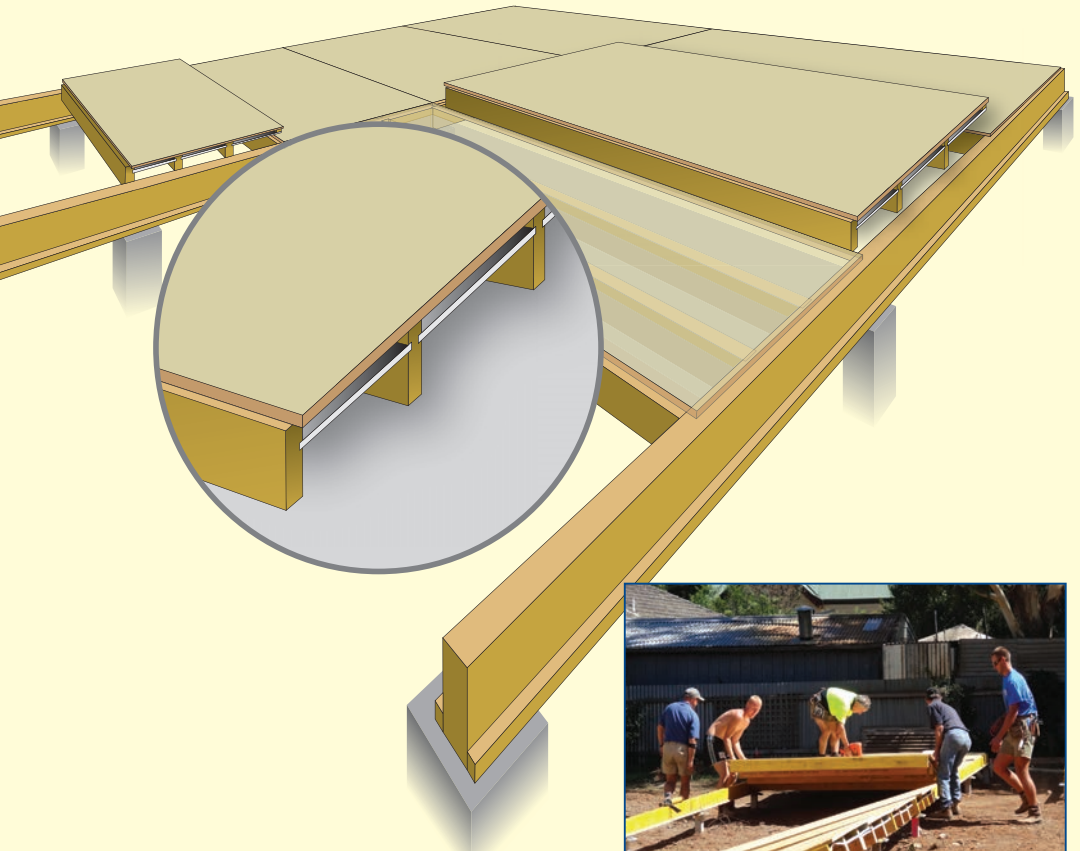

- Natural carbon store from renewable resources
- Fast installation – dimensionally accurate and level
- Six Star Energy rating
- PEFC/FSC Certified Engineered Timber
- Precision factory manufactured
- Australian designed



Qikfit Floors™

Qikfit Floors is a patent pending, low profile, prefabricated timber floor system. Australian Engineered and developed over many years, Qikfit was first installed in Melbourne in early 2003. Advances in engineered timber and insulation materials have made it possible to now meet the increasing demand for simple, fast and cost effective floor construction.

Manufacture

Qikfit Floors are precision manufactured in our Bayswater factory ensuring a consistent, dimensionally accurate and high quality floor panel system consisting of:

- Pre-grooved engineered LVL joists.
- OSB flooring secured to the joists to create floor panels.
- Rigid insulation secured in joist channels.
- Modified LVL bearers.

This quality controlled manufacturing process ensures fast and trouble free on-site installation.



Environment

High Performance LVL and OSB panels manufactured from PEFC/FSC certified pine ensures Qikfit floor panels are not just strong but are also the right choice for the environment.

Not only do Qikfit Floors use over 6 times less CO2 to produce than concrete slabs, they also store about half their mass in carbon for the life of the floor.

Insulation

Qikfit Floors incorporate factory installed Foil Board Insulation panels enabling the system to achieve a minimum R2.3 value which equates to a Six Star Energy Rating.

This thermal rating also complies in most climate zones using the BASIX DIY method for NSW.

Installation/Construction

Once the builder has installed their stumps in accordance with the engineered stump layout supplied by Qikfit, floor assembly can commence. LVL bearers are placed and secured onto the stumps (typically in a 2.5m x 2.5m grid) in the required locations. The floor panels are then slotted into the bearers, glued and nailed off to complete the process. As with other common timber flooring products, Qikfit floors can be exposed to direct weathering for up to three months during standard construction.

There are many benefits in the installation and construction of Qikfit floor systems:

- Larger grid spacing means less stumps compared to conventional timber floors.
- Bearers can be easily adjusted on stumps as needed (using packing) to create a perfectly level floor.
- A level and dimensionally accurate floor simplifies the installation of wall frames and roof trusses.
- All components are a manageable weight, negating the need for cranes or specialised lifting equipment.
- Qikfit provides for a faster build as there is no need to wait for other trades to "rough-in" or the slab to "cure" before continuing.
- Platform floors are an optimum surface for all overlay flooring such as tiles and engineered or natural feature timber.
- The raised Qikfit floor allows for flexibility and on-site alterations or additions include plumbing, electrical, ducting, etc.
- Reduction of on-site waste due to off-site fabrication.

Engineering

Qikfit Floors has independent Engineering Certification to confirm compliance to all relevant Australian Building codes and Standards.

Qikfit™

FLOORS

Qikfit Floors Pty Ltd
3a 77-83 Bayfield Road East, Bayswater North Vic 3153
Ph: 9762 5217 - Fax: 9762 7735
email: info@qikfitfloors.com.au

Foil Board®
INSULATION PANEL
The smarter way to insulate



Developed as a pre-fabricated panelised floor system from 2000 – 2002
Qikfit is designed for fast, economical, on-site installation.
First project - Home extension installed in Box Hill in Early 2003



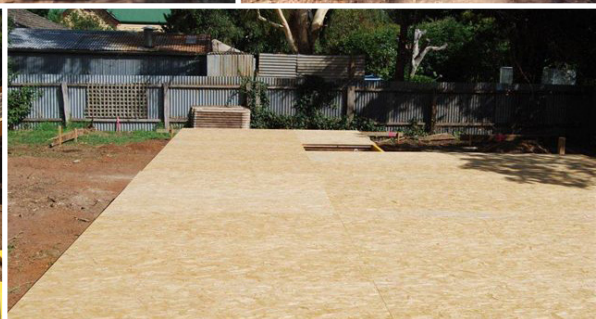

JOIST 130mm x 45mm LVL
SINGLE REBATE

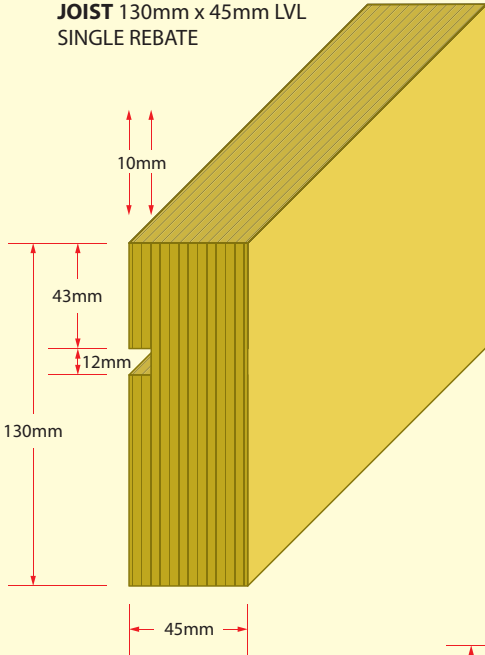

JOIST 130mm x 45mm LVL
DOUBLE REBATE

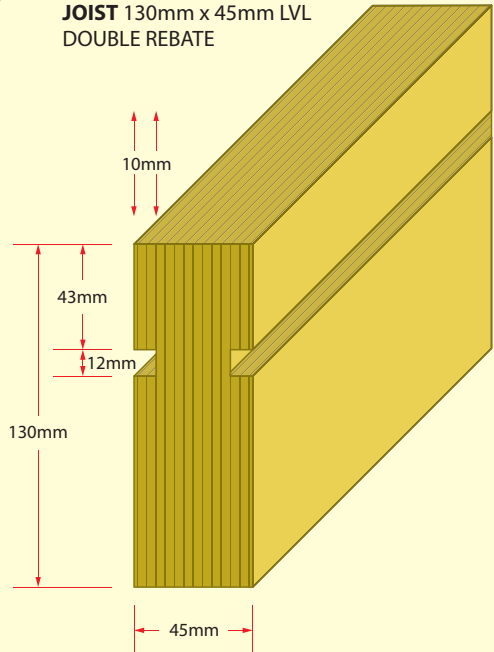



**Consulting, Structural &
Geotechnical Engineers**

17 King Street
BLACKBURN VIC 3130
Tel: (03) 9955 0090
Fax: (03) 9955 0094

A.B.N. 55 006 703 108

E-mail: office@tgaengineers.com

STRUCTURAL CERTIFICATION

Tim Gibney & Associates Pty Ltd prepared the structural design and certification for the Qikfit Floors in accordance with structural engineering principles and the relevant Australian Building Codes and Standards.

The strength and serviceability parameters have been checked in accordance with the manufacturer's material properties and the structural design is in accordance with AS 1720.1.

The serviceability requirements have been checked in accordance with AS 1684-2002 SAA Timber Construction Structures Code.

References:

1. AS 1170.1-2011 SAA Loading Code Part 1 Dead and Live Loads and Load Combinations
2. AS 1170.2-2011 SAA Loading Code Part 2 Wind Loads
3. AS 1720.1-2010 SAA Timber Structures Code Part 1 Design Methods
4. AS 1684.2-2009 SAA Timber Construction Structures Code

Tim Gibney F.I.E. (Aust) C.P. Eng
NPER-3 Registered
Registered Building Practitioner, Victoria
Building Practitioners Board No. EC-1354